

FITTING INSTRUCTION

Clamp mark in acc. with		Cables joining
ISO	PN	
1	L	Left directional lights
2	+	Rear fog lights
3	31	Ground
4	R	Right directional lights
5	58R	Right side parking lights
6	54	Stoplights
7	58L	Left side parking lights

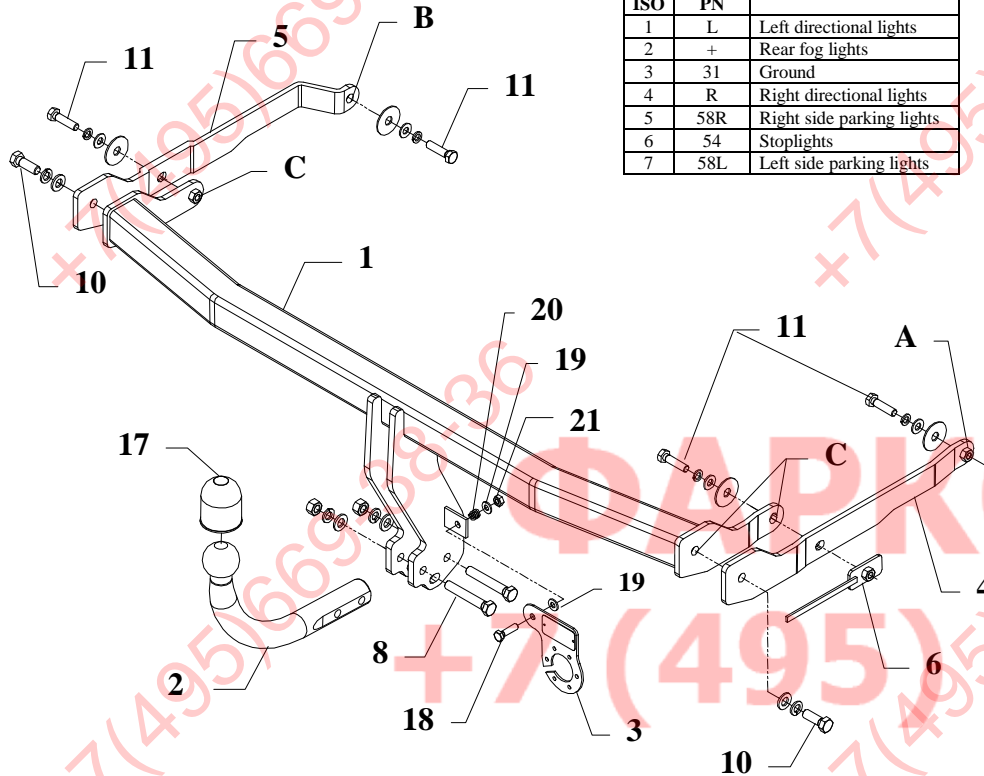

This towbar is designed to assembly in following car:
RENAULT MEGANE 5 door, produced since 11.2002 till 2008,
 catalogue no. **G41** and is prepared to tow trailers max total weight **1300 kg**
 and max vertical load **75 kg**.

From manufacturer

Thank you for buying our product. Their reliability has been confirmed in many tests. Reliability of towbar depends also on correct assembly and right operation. For this reasons we kindly ask to read carefully this instruction and apply to hints.

The towbar should be install in points described by a car producer.

The instruction of the assembly

- Disassemble the bumper and unscrew original aluminium bumper's reinforcement (this part is not used any more).
- The act of assembling is possible from the inside part of the boot:
 - Find two original holes cover with the string on the right side of the chassis member,
 - Find one hole on the left side – make it available, the second hole is seen from outside.
- Slide the element (pos. 4) to the right chassis member, and fix it loosely through the holes (pos. A).
- Slide the element (pos. 5) to the left chassis member, and fix it loosely through the holes (pos. B).
- Then fix the main bar of towbar (pos. 1) through the holes (pos. C – see the drawing).
- Position the ball of towbar (pos. 2) and fix it with bolts M12x75mm (pos. 8) and M12x70mm (pos. 9) from the towbar accessories.
- Fix the socket plate (pos. 3) as shown on the drawing.
- Cut the bumper.
- Reassemble the bumper.
- Tighten all nuts and bolts according to the torque shown in the table.
- Connect the electric wires according to the instructions of the car.
- Complete the paint cover of towbar (during the mounting paint cover could be destroyed).

Torque settings for nuts and bolts (8,8):	
M 8 - 25 Nm	M 10 - 55 Nm
M 12 - 85 Nm	M 14 - 135 Nm











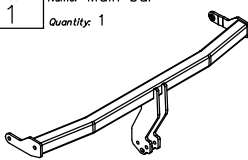
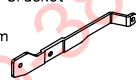

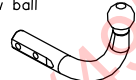



NOTE

After install the towbar you should get adequate note in registration book (at authorised service station).The car should be equipped with:

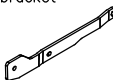
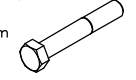
- Indicators
- Tow mirrors

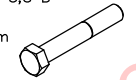
After 1000km of exploitation check all bolts and nuts. The ball of towbar must be always kept clear and conserve with a grease.

Towbar accessories:

Pos. 1 Name: Main bar Quantity: 1 	Pos. 5 Name: Left bracket Quantity: 1 Dim.: 480x75mm 	Pos. 10 Name: Bolt 8,8 B Quantity: 2 Dim.: M12x35mm 	Pos. 16 Name: Spring washer Quantity: 4 Dim.: Ø 10,2 mm 
Pos. 2 Name: Tow ball Quantity: 1 	Pos. 6 Name: Jib with the nut Quantity: 1 Dim.: M10, L=180mm 	Pos. 11 Name: Bolt 8,8 B Quantity: 4 Dim.: M10x40mm 	Pos. 17 Name: Ball cover Quantity: 1 
Pos. 3 Name: Socket plate Quantity: 1 	Pos. 7 Name: Washer Quantity: 4 Dim.: Ø37xØ13x3mm 	Pos. 12 Name: Nut 8 B Quantity: 2 Dim.: M12 	Pos. 18 Name: Bolt 8,8 B Quantity: 1 Dim.: M8x30mm 
Pos. 4 Name: Right bracket Quantity: 1 Dim.: 480x75mm 	Pos. 8 Name: Bolt 8,8 B Quantity: 1 Dim.: M12x75mm 	Pos. 13 Name: Plain washer Quantity: 4 Dim.: Ø 13 mm 	Pos. 19 Name: Plain washer Quantity: 2 Dim.: Ø 8,5 mm 
	Pos. 9 Name: Bolt 8,8 B Quantity: 1 Dim.: M12x70mm 	Pos. 14 Name: Plain washer Quantity: 4 Dim.: Ø 10,5 mm 	Pos. 20 Name: Spring Quantity: 1 
		Pos. 15 Name: Spring washer Quantity: 4 Dim.: Ø 12,2 mm 	Pos. 21 Name: Nut 8 B Quantity: 1 Dim.: M8 



PPUH AUTO-HAK S. J.

Produkcja Zaczepów Kulowych
Henryk & Zbigniew Nejman
76-200 SŁUPSK ul. Słoneczna 16K
tel/fax (059) 8-414-414; 8-414-413
E-mail: office@autohak.com.pl
www.autohak.com.pl

Towing hitch (without electrical set)

Class: **A50-X** Cat. no. **G41**

Designed for:

Manufacturer: **RENAULT**

Model: **MEGANE**

Type: **5 door**

produced since 11.2002 till 2008

Approval number acc. to regulations EKG/ONZ 55.01: **E20-55R-01 0854**

Technical data:

D-value: 7,44 kN

maximum trailer weight: **1300 kg**

maximum vertical cup load: **75 kg**

Foreword

This towbar is designed according to rules of safety traffic regulations. The towing hitch is a safety component and must be installed only by qualified personnel. Any alteration or conversion to the towing hitch is prohibited and would lead to cancellation of design certification. Remove insulating compound and underseal from vehicle (if present) in the area of the matting surfaces of the towing hitch.

The vehicle manufacturer's specifications regarding trailer load and max. vertical cup load are decisive for driving, and values for the towing hitch cannot be exceeded.

D-value formula:

$$\frac{\text{Max trailer weight [kg]} \times \text{Max vehicle weight [kg]} \times 9,81}{\text{Max trailer weight [kg]} + \text{Max vehicle weight [kg]} + 1000} = D \text{ [kN]}$$